

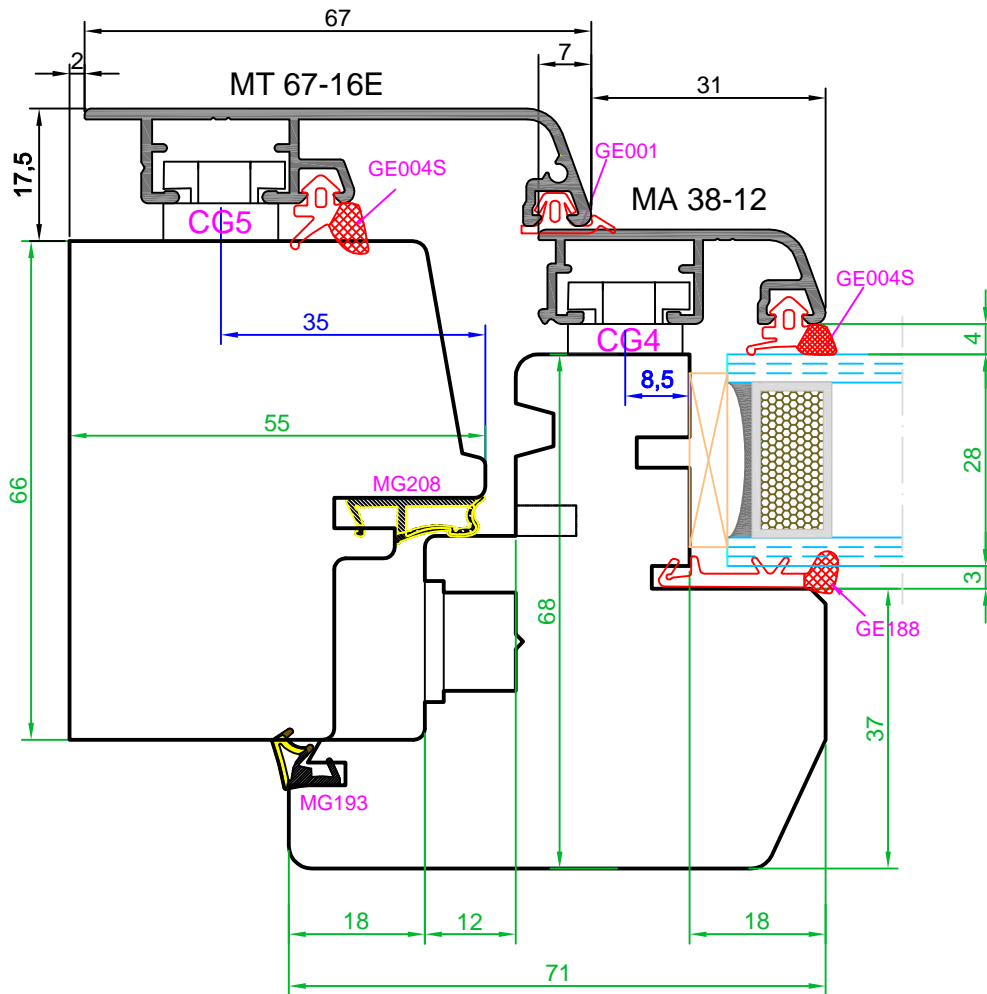

miniSOCIAL	CLIENTE: ANGER	DESCRIZIONE: NODO INFERIORE
	CODICE PROGETTO: 02042021	
SCALA: 1:1	ESEGUITO DA: FABIO	 ANGER INFISSI IN LEGNO E LEGNO ALLUMINIO
	FOGLIO: 1.1	

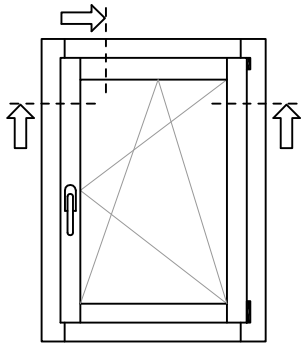

miniSOCIAL	CLIENTE: ANGER	DESCRIZIONE: NODO SUPERIORE E LATERALE
	CODICE PROGETTO: 02042021	
SCALA: 1:1	ESEGUITO DA: FABIO	 ANGER INFISSI IN LEGNO E LEGNO ALLUMINIO
	FOGLIO: 2	

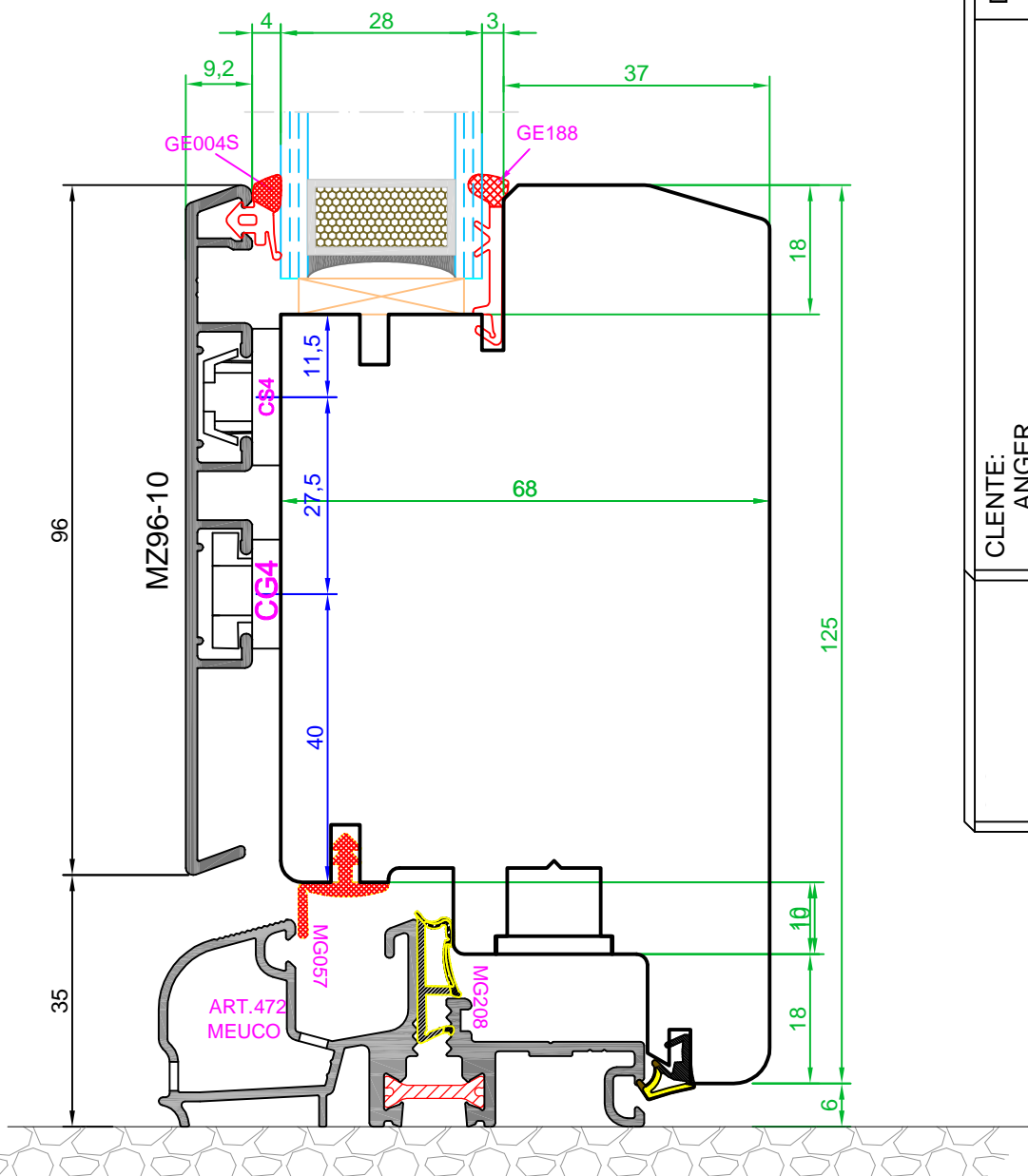
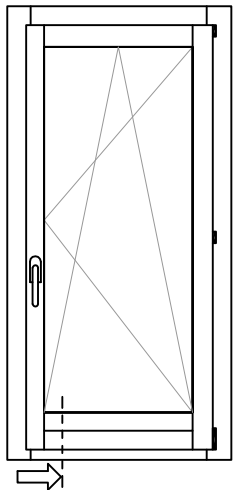

DESCRIZIONE:

NODO INFERIORE PORTAFINESTRA 1 ZOCC.



ANGER
INFISSI IN LEGNO E LEGNO ALLUMINIO

CLENTE:
ANGER

CODICE
02042021

PROGETTO:

ESEGUITO

DA: FABIO

FOGLIO: 4

SCALA:
1:1

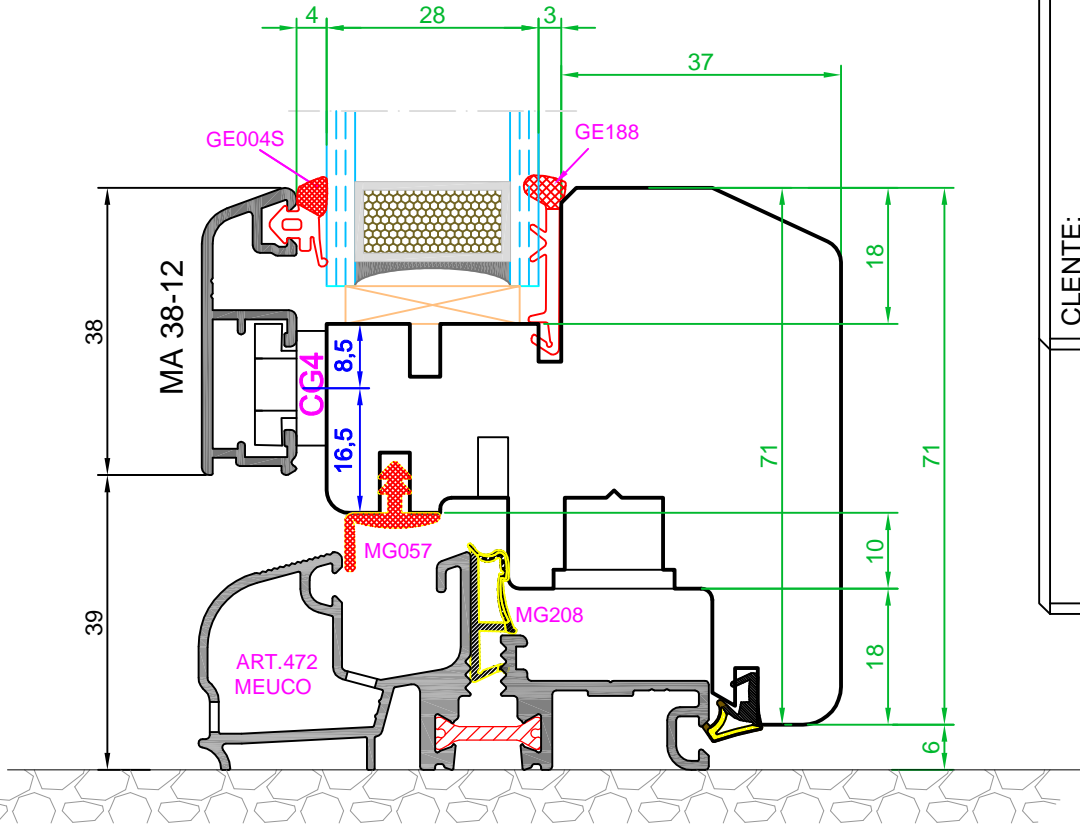
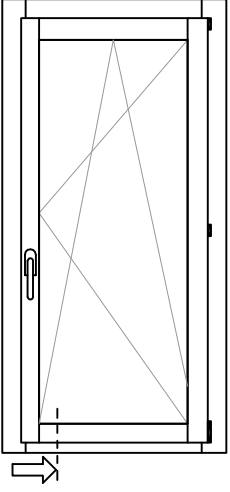

DESCRIZIONE: NODO INFERIORE PORTAFINESTRA SENZA ZOCC.	CLIENTE: ANGER	 ANGER INFISSI IN LEGNO E LEGNO ALLUMINIO
	CODICE: 02042021 PROGETTO: ESEGUITO: FABIO DA: FOGLIO: 5	
SCALA: 1:1		

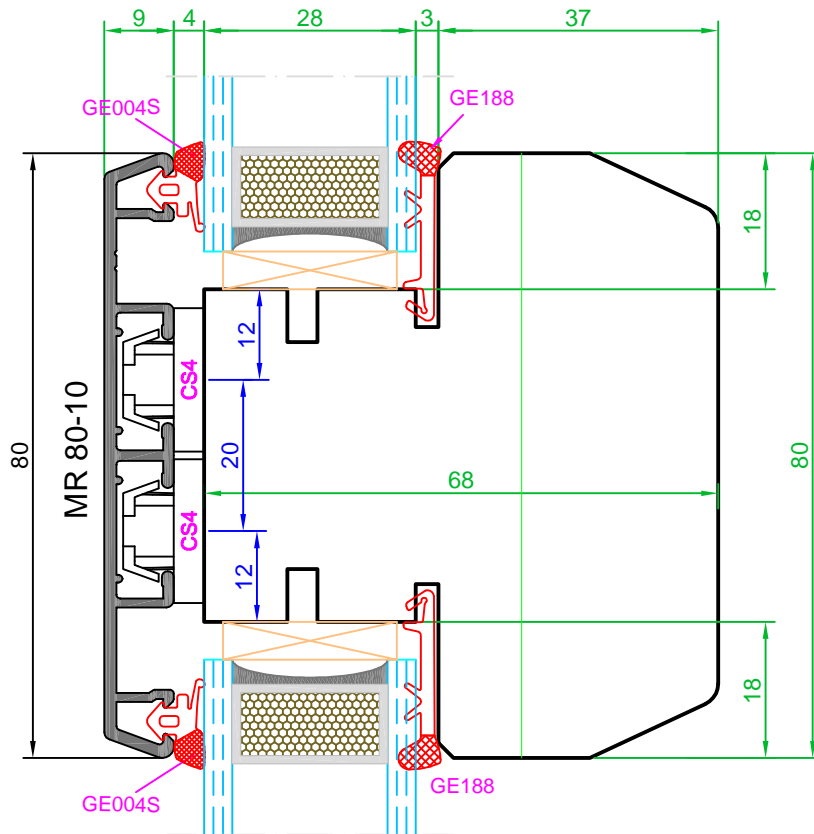
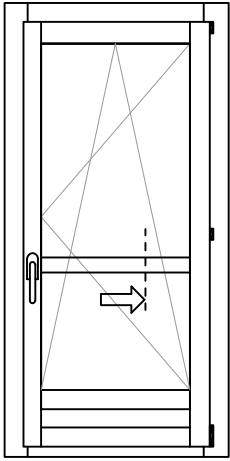

miniSOCIAL	CLIENTE: ANGER	DESCRIZIONE: ROMPI TRATTA
	CODICE PROGETTO: 02042021	
SCALA: 1:1	ESEGUITO DA: FABIO	
	FOGLIO: 6	

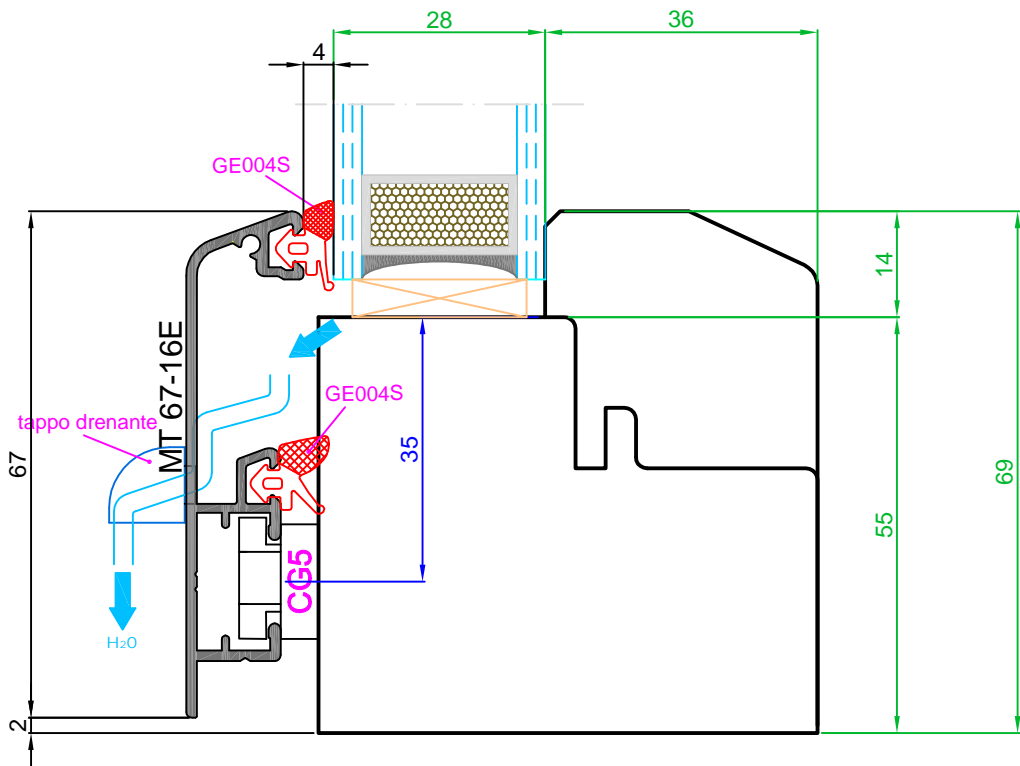
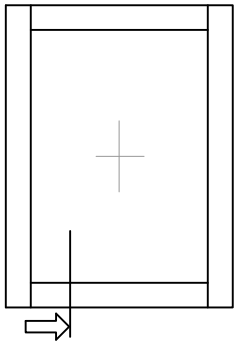

miniSOCIAL	CLENTE: ANGER	DESCRIZIONE: TELAIO FISSO
	CODICE PROGETTO: 02042021	 ANGER INFISSI IN LEGNO E LEGNO ALLUMINIO
SCALA: 1:1	ESEGUITO DA: FABIO	
	FOGLIO: 7	

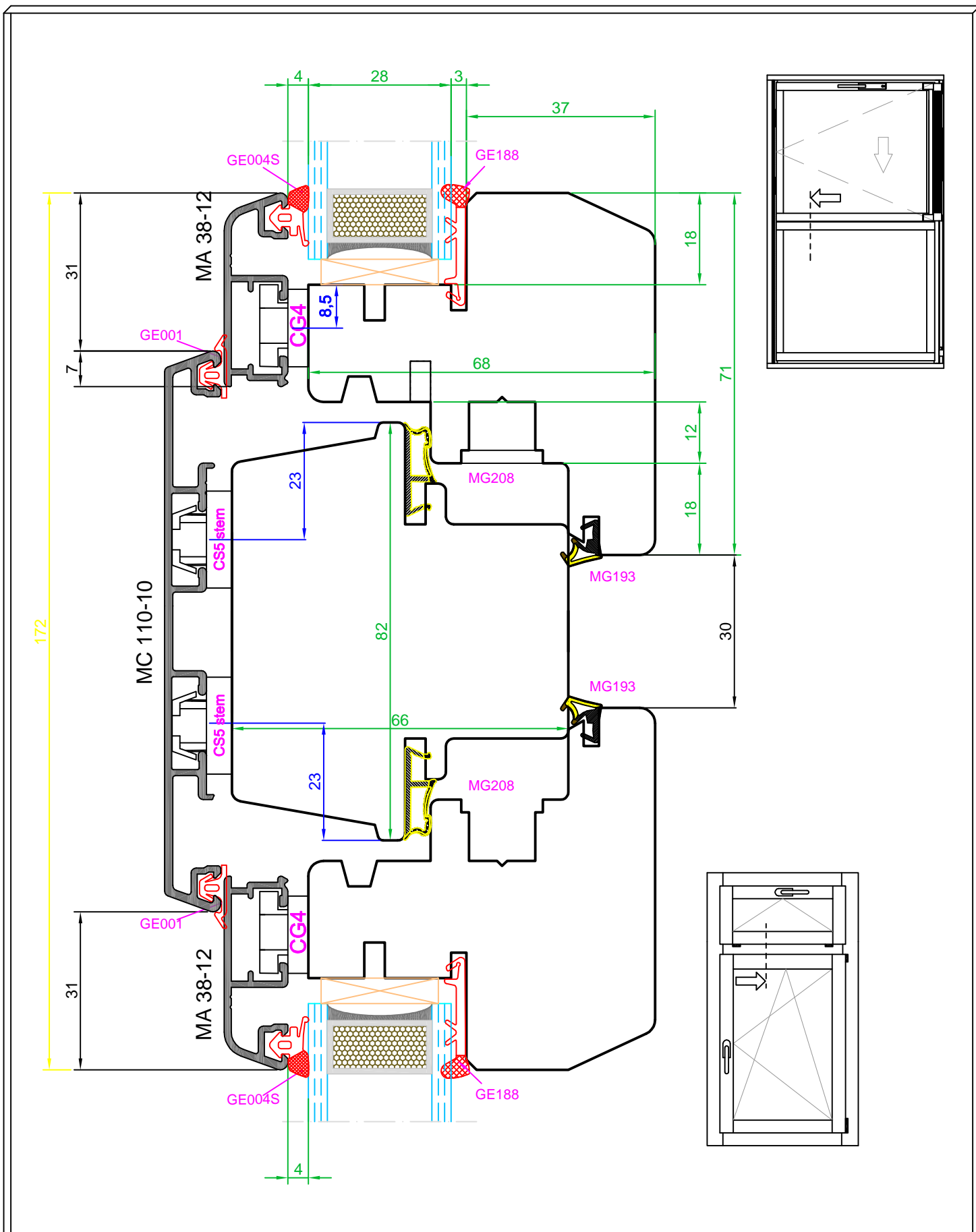

miniSOCIAL	CLIENTE: ANGER	DESCRIZIONE: piantone con sottoluce apribile o scorrevole parallelo
	CODICE PROGETTO: 02042021	
SCALA: 1:1	ESEGUITO DA: FABIO	
	FOGLIO: 8	

